



M CEMENT **IXER**



YONGKANG-CHINA

About us



Yongkang Xieheng Industry & Commerce Co., Ltd is a company specializing in manufacturing automotive service equipments and small construction machines.

We provide a range of high quality products for professional, rental and DIY users, Includes: parts washer, sandblaster, oil drainer, concrete mixer etc.

We hold a strong position for growth and operate with a focused new product development program. Designing right products for right market, we have a dedicated export team focusing their efforts on the international market, listening to our customer's voice and meeting their demand. We keep enhancing good reputation for honest and reliable business conduct among our worldwide customers.

We have established strict quality control system and our tenacious efforts can assure high quality and first-class products. We are looking forward to greater cooperation with overseas customers on the principle of mutual benefits. We warmly welcome you to visit our factory for business.



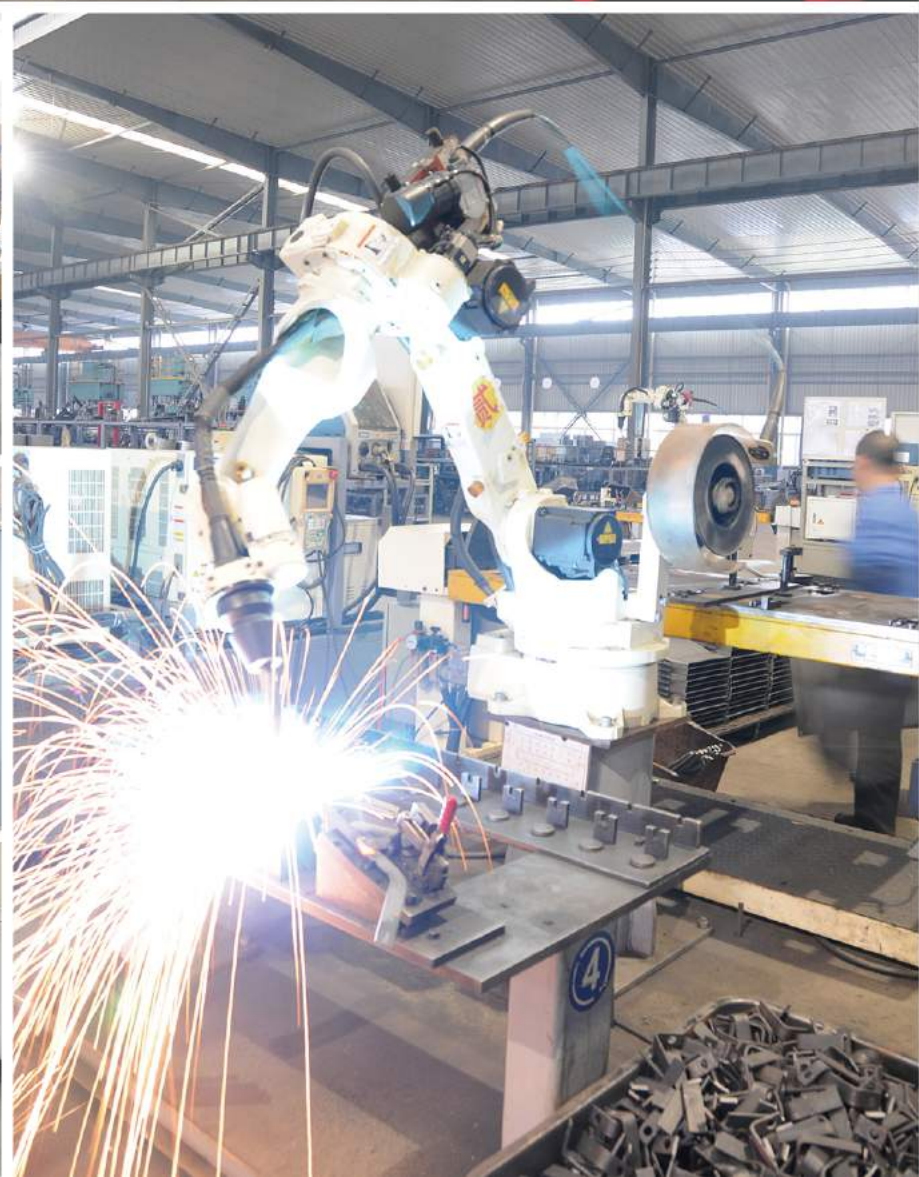

Portable Concrete Mixer 150



XH-PCM150



Specification:

- ◆ Wheels easy to transport
- ◆ Operating in confined spaces
- ◆ Easy access cover top for fuel and maintenance
- ◆ Proven gearbox
- ◆ Drum capacity:5 cubic feet
- ◆ Batch output:2.5cubic feet (275bs)
- ◆ Drum diameter:24/inch
- ◆ Discharge outlet height:32/inch
- ◆ Engine:2.5HP Gasoline
- ◆ Drum speed:24rpm

Function:

- ◆ Safe and simple assembly
- ◆ Portable and light,compact enough for the car boot
- ◆ Available boxed for easy stocking and transport
- ◆ Portable stand allows barrow height mixing and tipping
- ◆ Range of concrete mixers has proven appeal to the professional,rental and DIY
- ◆ Offer portable,quality mixers for any building requirement
- ◆ Light weight but effect the XH-PCM150 operates in confined spaces,at barrow height on the stand,or simply wheeled to the job
- ◆ The best marketing mixer for construction and rental

Item Number	Pcs/ctn	G.W./N.W.	Dimension	Q'ty/40HQ	Remarks
XH-PCM150	1	75/72kgs	80x66x86cm 93x66x93cm	147pcs 108pcs	

Horizontal Portable Concrete Mixer With Stander

CE

CONCRETE MIXER



XH-PCM5-HS

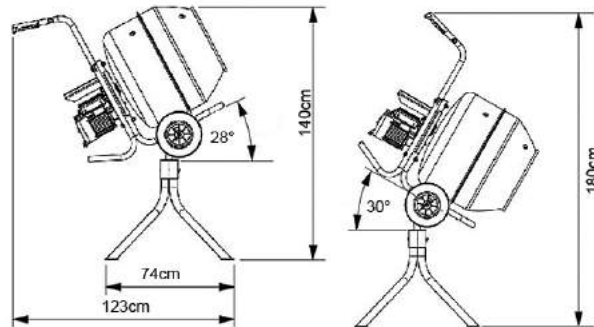

Function:

- ◆ Mix all types of construction materials in complete confidence
- ◆ Unit can be disassembled in 1 minute for fast transport

Cement Mixer Stander



XH-PCM-S

Specification:

- ◆ Drum Capacity(Cubic Feet):5
- ◆ Motor(HP):0.5
- ◆ Batch Output(lbs):275
- ◆ Batch capacity bag:1
- ◆ Drum diameter(in):24
- ◆ Discharge outlet height(in):8
- ◆ Wheel size(in):10x2.75
- ◆ Acceptable voltage:110-120v/60Hz,220-240V/50Hz
- ◆ Wheel barrow type multimixer

Item Number	Pcs/ctn	G.W./N.W.	Dimension	Q'ty/20'	Q'ty40HQ	Remarks
XH-PCM5-HS	1	72/68kgs	72x66x66cm	72pcs	204pcs	

Item Number	Pcs/ctn	G.W./N.W.	Dimension	Remarks
XH-PCM-S	1	12/11kgs	75x20x19cm	

Horizontal Portable Concrete Mixer With Stander

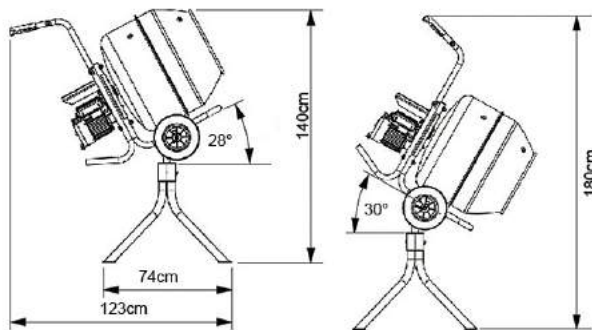

XH-PCM5-PE



Function:

- ◆ Mix all types of construction materials in complete confidence
- ◆ Unit can be disassembled in 1 minute for fast transport

Specification:

- ◆ Drum Capacity(Cubic Feet):5
- ◆ Motor(HP):0.5
- ◆ Batch Output(lbs):275
- ◆ Batch capacity bag:1
- ◆ Drum diameter(in):24
- ◆ Discharge outlet height(in):8
- ◆ Wheel size(in): 10x2.75
- ◆ Acceptable voltage: 110-120v/60Hz, 220-240V/50Hz
- ◆ Wheel barrow type multimixer

Item Number	Pcs/ctn	G.W./N.W.	Dimension	Q'ty40HQ	Remarks
XH-PCM5-PE	1	75/72kgs	80x66x86cm	147pcs	
	1	75/72kgs	93x66x93cm	108pcs	



XH-PCM8-V

Function:

- ◆ Mix all types of construction materials in complete confidence
- ◆ Unit can be disassembled in 1 minute for fast transport

Specification:

- ◆ Drum Capacity(Cubic Feet):8
- ◆ Motor(HP):0.75(50Hz)/0.5(60Hz)
- ◆ Batch Output(lbs):400
- ◆ Batch capacity bag:1
- ◆ Drum diameter(in):28
- ◆ Discharge outlet height(in):8
- ◆ Wheel size(in):12x3
- ◆ Acceptable voltage:110-120v/60Hz,220-240V/50Hz
- ◆ Mixing capacity :3.6cubic or 360pounds
- ◆ Drum rotation:23R.P.M

Item Number	Pcs/ctn	G.W./N.W.	Dimension	Q'ty/20'	Q'ty/40HQ	Remarks
XH-PCM8-V	1	66/62kg	74x74x75cm	72pcs	144pcs	

Vertical Portable Concrete Mixer

CE



XH-PCM5-V



XH-PCM5-V-II



Function:

- ◆ Out of the box and ready to go in 15 minutes
- ◆ Can be disassembled in 1 minute for transport
- ◆ Easy dump control handle

Specification:

- ◆ Drum Capacity(Cubic Feet):5
- ◆ Motor(HP):0.5
- ◆ Batch Output(lbs):275
- ◆ Batch capacity bag:1
- ◆ Drum diameter(in):24
- ◆ Discharge outlet height(in):21
- ◆ Wheel size(in):10x2.75
- ◆ Acceptable voltage:110-120v/60Hz,220-240V/50Hz
- ◆ Drum materials all steel construction
- ◆ Include tripod stand



Item Number	Pcs/ctn	G.W./N.W.	Dimension	Q'ty/20'	Q'ty/40'	Q'ty40HQ	Remarks
XH-PCM5-V	1	55/51kgs	64x64x66cm	81pcs	162pcs	216pcs	
XH-PCM5-V-II	1	57/54kgs	64x64x66cm	81pcs	162pcs	216pcs	

Horizontal Portable Concrete Mixer

CE

CONCRETE MIXER



XH-PCM8-H

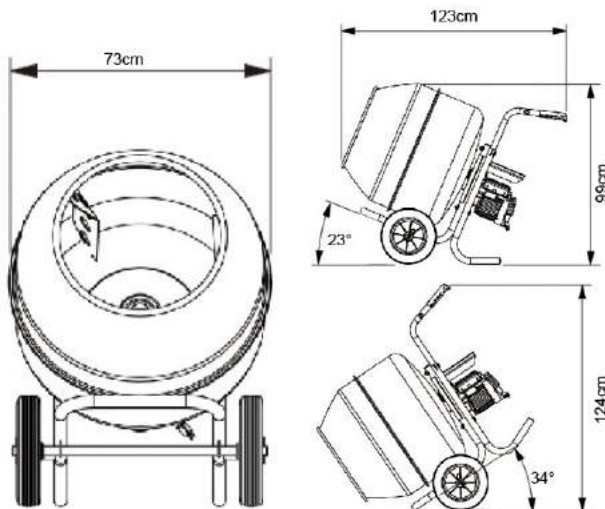

Function:

- ◆ Wheel barrow type multimixer
- ◆ Mix all types of construction materials in complete confidence
- ◆ Unit can be disassembled in 1 minute for fast transport

Specification:

- ◆ Drum Capacity(Cubic Feet):8
- ◆ Motor(HP):0.75Hp(50Hz)/0.5Hp(60Hz)
- ◆ Batch Output(lbs):400
- ◆ Batch capacity bag:1
- ◆ Drum diameter(in):28
- ◆ Discharge outlet height(in):8
- ◆ Wheel size(in):12x3
- ◆ Acceptable voltage:110-120v/60Hz(0.5),220-240V/50Hz(0.75)
- ◆ Mixing capacity :3.6cubic or 360pounds
- ◆ Drum rotation:23R.P.M



Item Number	Pcs/ctn	G.W./N.W.	Dimension	Q'ty/20'	Q'ty/40'	Remarks
XH-PCM8-H	1	69/65kg	80x74x76cm	63pcs	126pcs	

Horizontal Portable Concrete Mixer



XH-PCM5-H

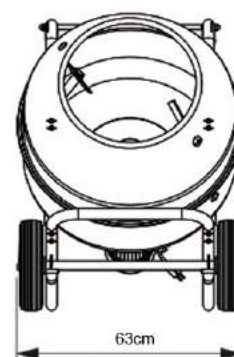
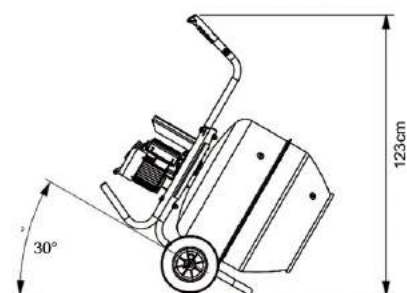
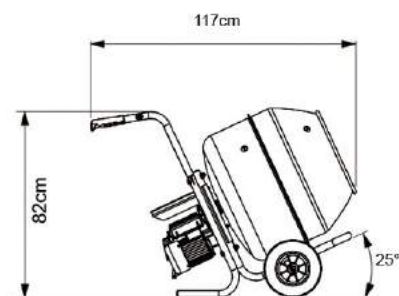

Function:

- ◆ Mix all types of construction materials in complete confidence
- ◆ Unit can be disassembled in 1 minute for fast transport

Specification:

- ◆ Drum Capacity(Cubic Feet):5
- ◆ Motor(HP):0.5
- ◆ Batch Output(lbs):275
- ◆ Batch capacity bag:1
- ◆ Drum diameter(in):24
- ◆ Discharge outlet height(in):8
- ◆ Wheel size(in):10x2.75
- ◆ Acceptable voltage:110-120v/60Hz,220-240V/50Hz

Item Number	Pcs/ctn	G.W./N.W.	Dimension	Q'ty/20'	Q'ty/40'	Q'ty40HQ	Remarks
XH-PCM5-H	1	56/52kgs	66x64x66cm	81pcs	162pcs	216pcs	

Portable Concrete Mixer



XH-PCM3-1/2



Specification:

- ◆ Handle 34kgs,bags of dry cement or mortar mix
- ◆ 1/3 HP motor develops 1440 RPM(110V)/1680RPM(230V)
- ◆ Rolls easily around the job site
- ◆ All steel constructions
- ◆ Base is 122x82cm
- ◆ Drum opening is 38cm
- ◆ Gross Drum volume:50litres/1.8cu.ft
- ◆ Drum rotation:28RPM
- ◆ Drum diameter:39cm

Item Number	Pcs/ctn	G.W./N.W.	Dimension	Q'ty/20'	Q'ty/40'	Remarks
XH-PCM3-1/2	1	34/32kgs	64x55x34cm	252pcs	504pcs	
	1	36/33kgs	85x56x86cm	56pcs	112pcs	

Horizontal Portable Concrete Mixer



XH-PCM3-1/2-II



Specification:

- ◆ Handle 34kgs,bags of dry cement or mortar mix
- ◆ 1/3 HP motor develops 1440 RPM(110V)/1680RPM(230V)
- ◆ Rolls easily around the job site
- ◆ All steel constructions
- ◆ Base is 122x82cm
- ◆ Drum opening is 38cm
- ◆ Gross Drum volume:50litres/1.8cu.ft
- ◆ Drum rotation:28RPM
- ◆ Drum diameter:39cm

Item Number	Pcs/ctn	G.W./N.W.	Dimension	Q'ty/20'	Q'ty/40'	Remarks
XH-PCM3-1/2-II	1	35/33kgs	64x55x34cm	252pcs	504pcs	
	1	37/34kgs	85x56x86cm	56pcs	112pcs	

Concrete Mixer

CE

CONCRETE MIXER



XH-PCM130

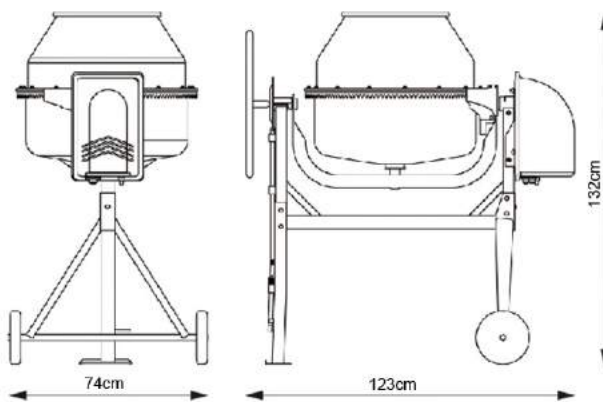

Specification:

- ◆ Heavy duty & Easy use product
- ◆ Industrial Nylon ring gear ensuring anti-rust & low noise
- ◆ High quality motor with 100% copper material
- ◆ Drum opening: 370mm
- ◆ Drum speed: 25-30RPM(50Hz)/30-36RPM(60Hz)

Item Number	Drum Capacity	Motor Power	Pcs/ctn	G.W./N.W.	Dimension	Q'ty/20'	Q'ty/40'	Remarks
XH-PCM130	130L	500W	1	59/56kgs	83x70x60cm	76pcs	153pcs	

Concrete Mixer

CE



XH-PCM170

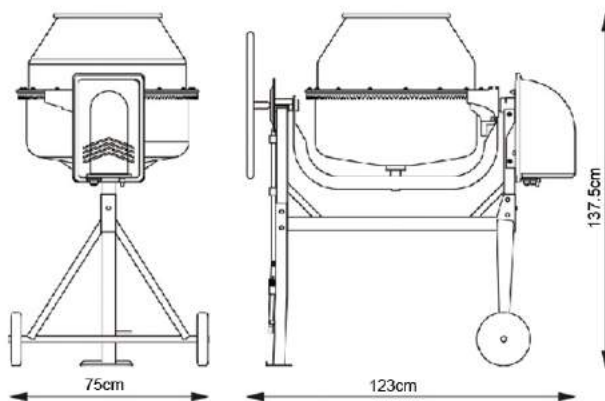

Specification:

- ◆ Heavy duty & Easy use product
- ◆ Industrial Nylon ring gear ensuring anti-rust & low noise
- ◆ High quality motor with 100% copper material
- ◆ Drum opening: 370mm
- ◆ Drum speed: 25-30RPM(50Hz)/30-36RPM(60Hz)

Item Number	Drum Capacity	Motor Power	Pcs/ctn	G.W./N.W.	Dimension	Q'ty/20'	Q'ty/40'	Remarks
XH-PCM170	170L	650W	1	62/59kgs	81x70x52.5cm	76pcs	153pcs	

Concrete Mixer

CE

CONCRETE MIXER



XH-PCM190

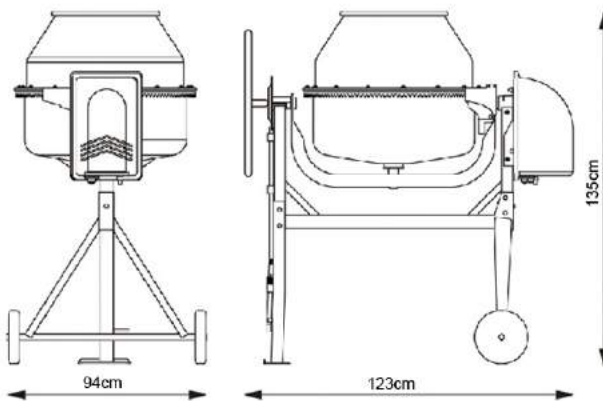

Specification:

- ◆ Heavy duty & Easy use product
- ◆ Industrial Nylon ring gear ensuring anti-rust & low noise
- ◆ High quality motor with 100% copper material
- ◆ Drum opening: 380mm
- ◆ Drum speed: 25-30RPM(50Hz)/30-36RPM(60Hz)

Item Number	Drum Capacity	Motor Power	Pcs/ctn	G.W./N.W.	Dimension	Q'ty/20'	Q'ty/40'	Remarks
XH-PCM190	190L	750W	1	75/72kgs	84x72x54.5cm	84pcs	153pcs	

Concrete Mixer

CE



XH-PCM210

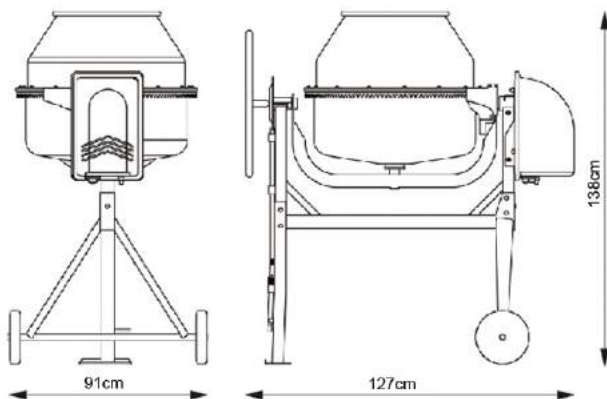

Specification:

- ◆ Heavy duty & Easy use product
- ◆ Industrial Nylon ring gear ensuring anti-rust & low noise
- ◆ High quality motor with 100% copper material
- ◆ Drum opening: 445mm
- ◆ Drum speed: 25-30RPM(50Hz)/30-36RPM(60Hz)

Item Number	Drum Capacity	Motor Power	Pcs/ctn	G.W./N.W.	Dimension	Q'ty/20'	Q'ty/40'	Remarks
XH-PCM210	210L	850W	1	76/71kgs	88x77x55cm	72pcs	156pcs	

Concrete Mixer

CE

CONCRETE MIXER



XH-PCM250

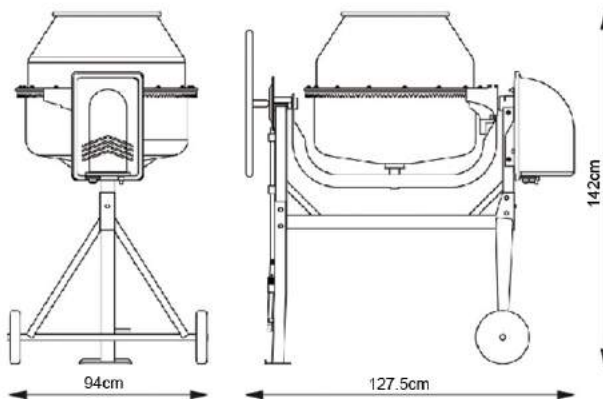

Specification:

- ◆ Heavy duty & Easy use product
- ◆ Industrial Nylon ring gear ensuring anti-rust & low noise
- ◆ High quality motor with 100% copper material
- ◆ Drum opening: 445mm
- ◆ Drum speed: 25-30RPM(50Hz)/30-36RPM(60Hz)

Item Number	Drum Capacity	Motor Power	Pcs/ctn	G.W./N.W.	Dimension	Q'ty/20'	Q'ty/40'	Remarks
XH-PCM250	250L	1000W	1	81/78kgs	81x80x56.5cm	76pcs	153pcs	

Portable Mortar Mixer

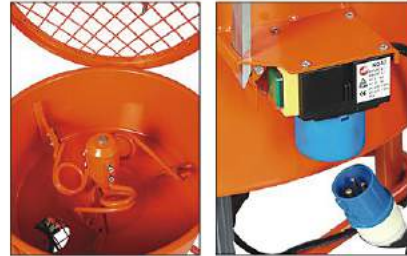

XH-PCM120

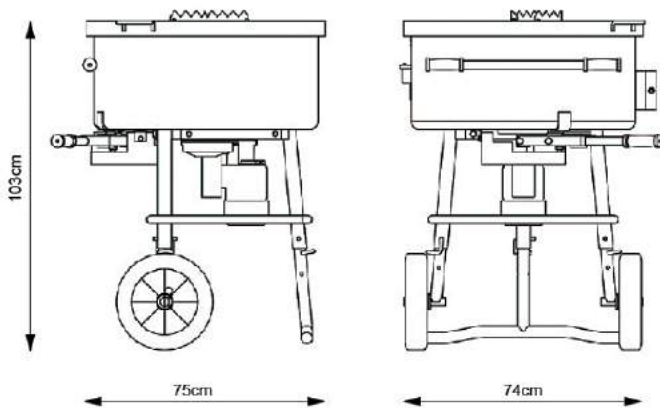

Specification:

- ◆ The machine is perfect for the 2-3 persons construction crew. Why go through all the hassles of towing a mixer to the job site, when the machine can make a wheelbarrow of mortar, stucco, grout or dry pack mortar every 3 minutes
- ◆ Drum capacity: 120 liter
- ◆ Batch output: 60 liter / 175 lbs
- ◆ Motor rating: 2.2HP
- ◆ Paddle speed: 32rpm
- ◆ Drum diameter: 27"
- ◆ Wheel size: 12"
- ◆ Motor Power: 1600W
- ◆ Voltage: 230V/110V
- ◆ Frequency: 50Hz/60Hz

Item Number	Pcs/ctn	G.W./N.W.	Dimension	Q'ty/20'	Q'ty/40'	Remarks
XH-PCM120	1	125/100kgs	77x77x85cm	42pcs	135pcs	

Luxury Concrete Mixer With Briggs & Stratton Petrol Engine



XH-PCM250-BE



Specification:

- ◆ Heavy duty & High quality product
- ◆ Tipping wheels, industrial Nylon ring gear
- ◆ Easy use with water proof engine cover
- ◆ 3.5Hp Briggs & Stratton petrol engine, Engine Model/83100
- ◆ Drum capacity: 250L
- ◆ Drum opening: 445mm
- ◆ Drum speed: 30rpm

Item Number	Pcs/ctn	G.W./N.W.	Dimension	Q'ty/20'	Q'ty/40'	Remarks
XH-PCM250-BE	1/2	92/84kgs	88x77x58.5cm 43x43x44cm	60pcs	116pcs	

WE ALSO HAVE GARAGE EQUIPMENT PRODUCTS...

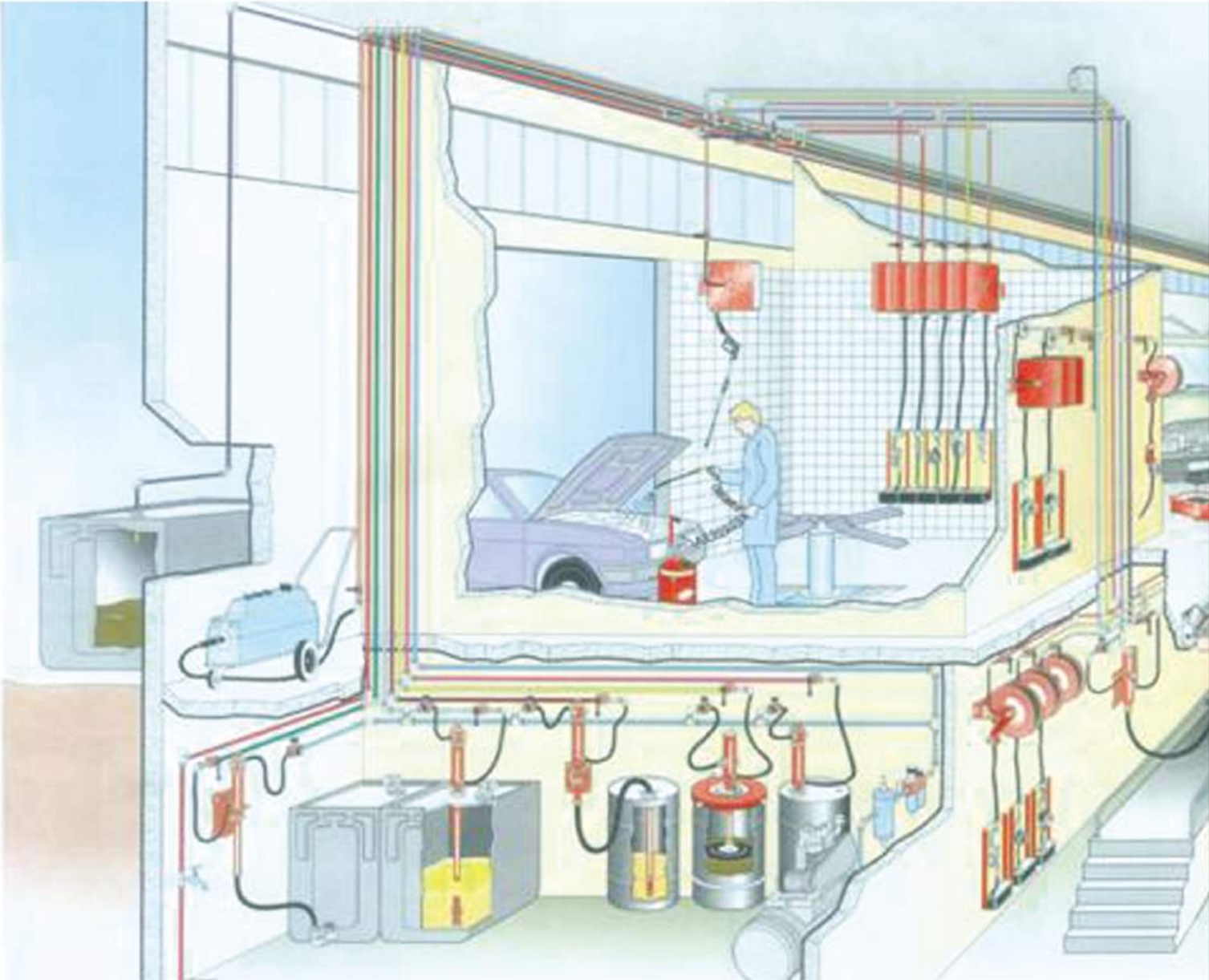





xieheng
协恒实业

YONGKANG XIEHENG ZHEJIANG PROVINCE INDUSTRY & COMMERCE CO.,LTD.



浙江省永康市协恒实业有限公司

YONGKANG XIEHENG ZHEJIANG PROVINCE INDUSTRY & COMMERCE CO.,LTD.

地址：浙江省永康市经济开发区锡山西路9号 | ADD:NO.9.XiShan West Road,Economic
Development,YongKang,ZheJiang,P.R.C.

电话 /TEL: 0086-579-87236198 87236167 | 传真 /Fax: 0086-579-87237009

邮箱 /E-mail: xieheng@xhtool.com | 邮编 /P.:321300